

MDSI Flat Lock Shingle Series 60

Installation Guidelines



**METAL
DESIGN
SYSTEMS**

**DESIGNED FOR
A PERFECT FIT.**

Metal Design Systems is pleased to offer an Installer's EDGE training course at our home office in Cedar Rapids, Iowa. This class is offered once a month free of charge to the installer. If you are interested in attending or would like more information, please contact MDSI via email at tech@crmdsi.com.

Metal Design Systems, Inc.

SERIES 60

Installation Guidelines

Required Equipment:

Forklift:

Typically crates are shipped directly to the job site from our fabrication facility via LTL carrier. This means that the crates will arrive in an enclosed trailer which will require either a dock and a forklift or an extended reach forklift in order to unload the crates. The average crate size is 4' x 10', but they can be up to 5' x 16'. Large shipments can be delivered on flat bed trucks if prior arrangements are made.

Man-lift/Scaffolding/Ladders:

The terrain, accessibility, quantity of work on each area, and height of work will typically determine the type of lift equipment required to complete each project. The preferred option will usually be an all terrain scissor lift because they offer a larger platform allowing for more work space and fewer moves.

Work Table:

You will need a work surface to prep the panels for installation, cut penetrations or make field modifications. The table should be large enough to safely support the largest panels on the project and be covered with a long pile carpet to protect the panels from damage. Some installers prefer to build tables on site using the crating materials. This is perfectly acceptable provided that they are constructed in a sturdy fashion.

Power Tools:

Compound miter saw or skill saw for cutting the panels and a Jig saw with plywood cutting blade for cutting penetrations in panels; router with carbide tipped, flat point V-bit; drill and various sized drill bits; screw gun with 5/16" hex head driver and #2 Phillips bit.

Hand Tools:

Pop-Rivet gun; rubber mallet; single-cut metal file; countersink bit; hole saw kit for penetrations; caulk gun; utility knife; single edge razor blades; tin snips; flat blade screw driver; tape measure; 4 foot level; torpedo level; (a laser or sight level can be very helpful for layout depending upon the complexity of the project); chalk line; safety glasses work gloves and hearing protection.

Supplies:

Always have an ample supply of fasteners in various sizes; plastic horseshoe shims in 1/4", 1/8" and 1/16" thicknesses; silicone sealant in the appropriate color; waterproof tarps to cover the crates and shop rags.

Crew Size:

A crew size of three typically works best in most cases. This allows for two in the lift handling and installing the panels on the wall and one on the ground prepping panels, cutting panels, and for general ground support.

Unloading:

Prior to unloading the crates from the delivery truck, inspect the crates for damage.

Note: Report any damage to the carrier and note the damage on the shipping tickets. The receiver must make all claims for damage through the carrier upon receipt. Metal Design Systems, Inc. is not responsible for any damage after the product leaves the factory.

Unload the material one crate at a time, know and follow all safety rules. Use the proper equipment for the weight being unloaded. If unloading with an overhead crane, use a spreader bar and nylon slings, do not "choke" the crates. Do not attempt to lift the crates by hand, drag, drop or stack the crates.

Inspection and Inventory:

Shipping damage should be noted on the Bill of Lading and then reported to Metal Design Systems.

Note: The customer is responsible for filing a claim for freight damage with the shipping company within 24 hours of receipt. Failure to do so, may result in forfeiture of the right to receive corrective action.

After verifying the condition of the product, inventory the panels and miscellaneous items and compare against the packing slip to ensure that all material is received.

Note: Notify Metal Design Systems immediately if the quantities received do not match the packing list. Failure to do so, may result in forfeiture of the right to receive corrective action.

Storage:

Store crates in a clean dry place. If the crates are to be stored outside, cover the crates to protect from the elements and ventilate to minimize heat build up (Figure 1). At the end of each work day, place loose panels back into the open crates, secure the panels, and cover the crate.

Figure 1

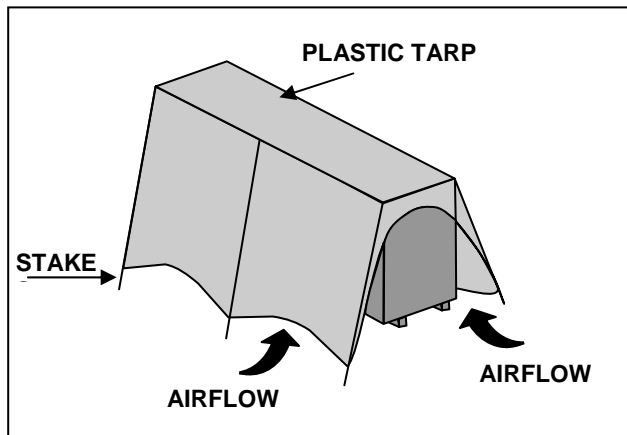

Shake Out:

Crate #1 will have a set of shop drawings revised to reflect field measurements and indicating panel part numbers and locations. Each crate will have a packing slip indicating the part numbers and quantities of the panels enclosed. At this time it may be beneficial to boldly write the contents of each crate on the outside for future reference. If possible, strategically place each crate in a

location convenient to the final destination of its contents.

Handling Individual Panels:

When removing panels from the crate, always take care to lift and clear other panels and sidewalls of the crate (Figure 2). Never slide or drag panels out of its location. When carrying a panel, always carry it “on edge” and never flat (Figure 3). Always be aware of your surroundings and take special care when handling panels that have intermediate routs or panels that have welded connections. Do not place the panels in any position that will cause the panel face or edges to come into contact with any surface that will cause damage to the protective film or panel finish. The protective film is designed to prevent minor abrasions. Extreme care should still be taken to avoid dents and scratches.

Figure 2

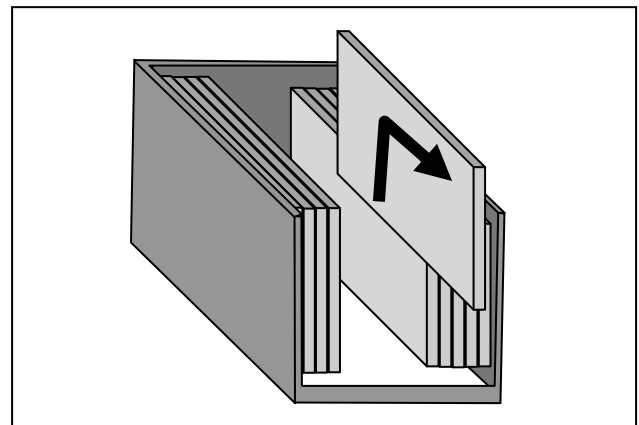
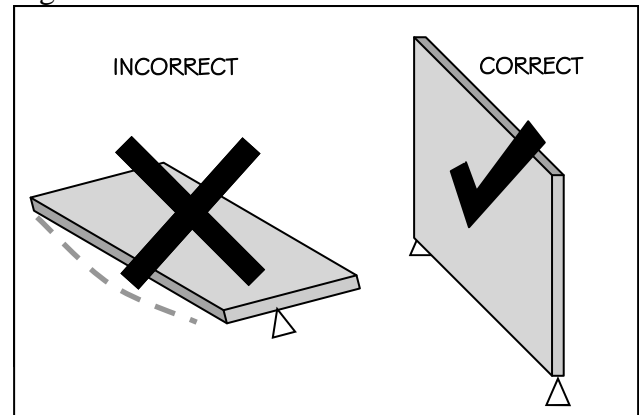

Figure 3



Substrate/Job Inspection:

Inspect the area that is to receive the panels to ensure that all work is complete and satisfactory. All substrates, weather barriers, penetrations, doors, windows, sill flashing, and any other adjacent materials should be in place and cleaned prior to proceeding with panel installation.

Note: Acid wash used for cleaning masonry will cause permanent damage to the panels.

Ensure that all surfaces are plumb, level, square, true, dry and free from defects. Do not begin installation until all unsatisfactory conditions have been corrected.

Layout:

Reference the shop drawings for either rectangular or square pattern of the shingles and the clip placement on the panels. Locate key components for shingle alignment (i.e. windows, doors, window mullions or other items that are critical to seam location) and begin layout from these locations. Snap level and plumb chalk lines at key rows and columns of shingles as well as every 3-4 units to ensure true level and plumb installation.

Installing Flashing & Weather Barrier:

Install flashing using standard sheet metal practices and procedures, ensuring that all joints and seams are weather lapped and sealed. For weather barrier, follow manufacture's written instructions for proper installation. Integrate weather barrier and flashing to allow proper drainage of any moisture that may get behind the shingles.

Installing Panels

Metal Design Systems Series 60:

Setting up:

Locate a work table, skill saw and jig saw in a safe and convenient location relative to the installation area. Have the clips provided available as well as the shop drawings to reference for clip placement on the panels and detail layouts.

Panel Prep:

Remove panels from crate and inspect again for damage. It is important that the protective film be left in place for as long as possible, however, it must be removed completely prior to installation. Do not install shingles with the film partially removed or only pulled back from the edges as this may cause uneven weathering if left too long. Use clean cotton gloves to keep the finish free from finger prints when handling shingles fabricated from natural metals such as Copper, Zinc, Stainless Steel, etc. These uncoated metals are especially susceptible to staining from dirt and oil during handling and installation.

Note: Panels with film left exposed to UV for extended periods of time may become difficult to remove. Panels with film partially removed and left exposed to UV may become discolored.

Installing J Channel:

Reference the shop drawings for the bottom edge where the shingles will begin and install the horizontal J channel provided, ensuring it is level. (Figure 4)

Figure 4

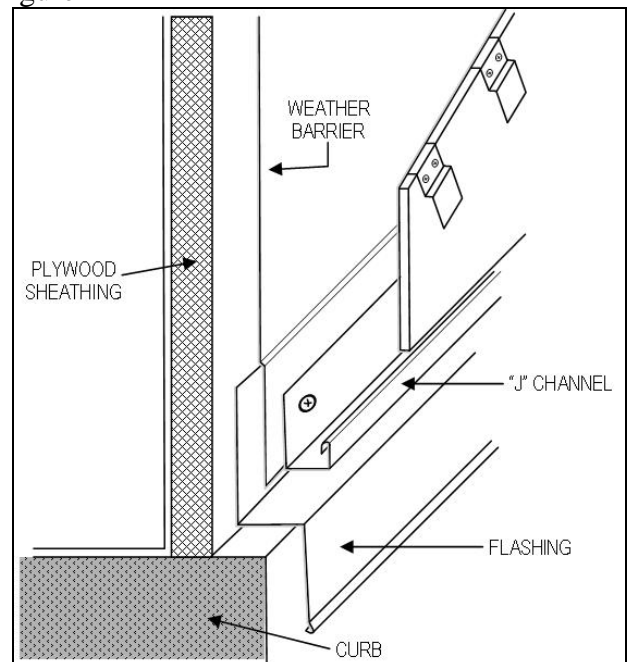

Starter Row:

Begin the installation with a starter row, created by cutting the shingles in half, just above the fabricated bend. (Figure 5)

Figure 5

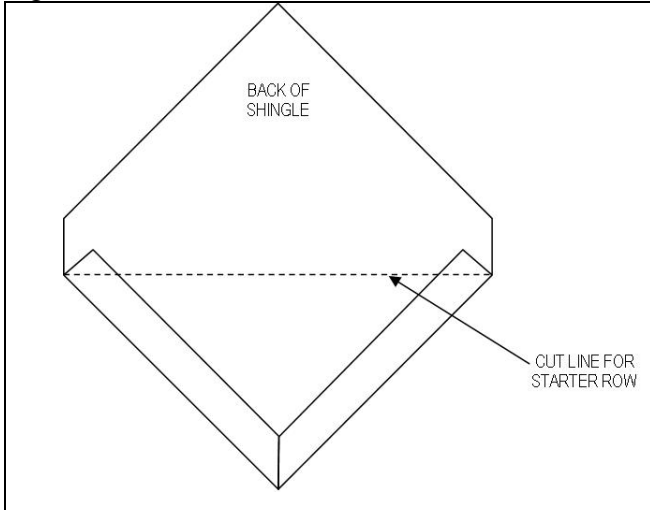

Remove the protective vinyl and install the starter row by placing the bottom straight edge of the flat, half cut shingles into the J channel and run a clip with fasteners into each side of the top of shingle. Butt each consecutive half shingle next to the previous one, working horizontally, until the starter row has been completed. Snap a vertical chalk line at every 3rd panel seam, making sure the lines are plumb. This will help to control shingle gain or loss over a long run. Horizontal level lines are also recommended. (Figure 6)

Figure 6

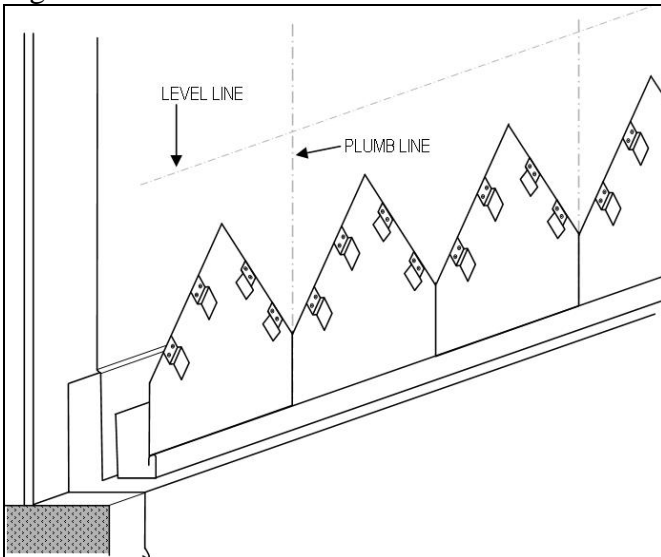

Panel Install:

From the starter row, engage the next shingle by allowing the bend on the back side of the shingle to hook and engage up into the clip. Push up until the shingle is snug and lines up with the layout lines. Place next clips and fasten to the wall. Continue across the starter row and work vertical, until all shingles are installed. (Figure 7, Figure 7A)

Figure 7

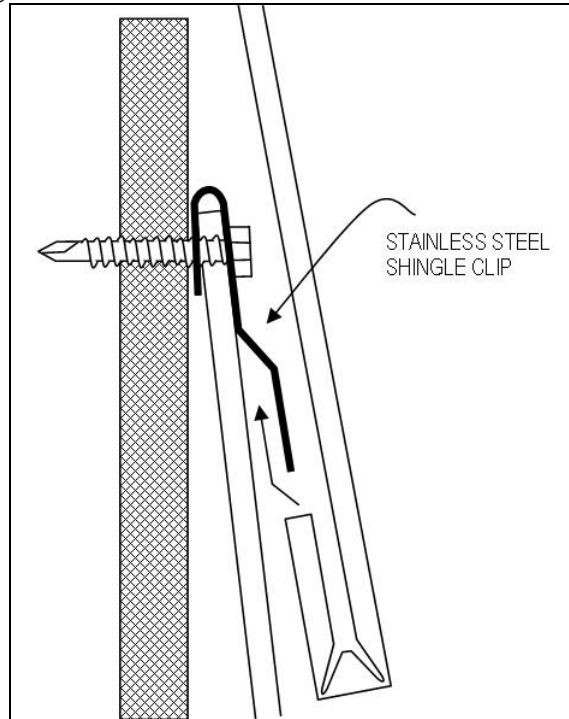
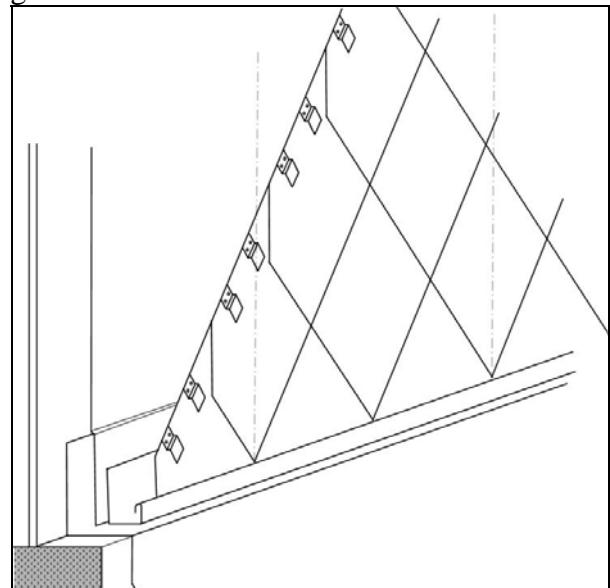

Figure 7A



Outside Corners:

Typically, an L trim will be provided to cover the raw edges at the outside corners. Field cut end shingles prior to final installation. NOTE: Do not remove the protective film until all field modifications are complete and shingle is ready for final installation. Engage the full panel into the clips and temporarily secure it in place. Draw a line on the back side of the panel to mark where it should be cut. Remove the panel, and cut along the line. Reinstall to check fit and make adjustments as necessary. Remove the protective vinyl film and secure the shingle with the clips and fasteners. Once the entire wall on both sides of the corner is complete, attach the included L shaped trim securing with rivets into the high points of the shingles to cover the raw seams. (Figure 8)

Figure 8

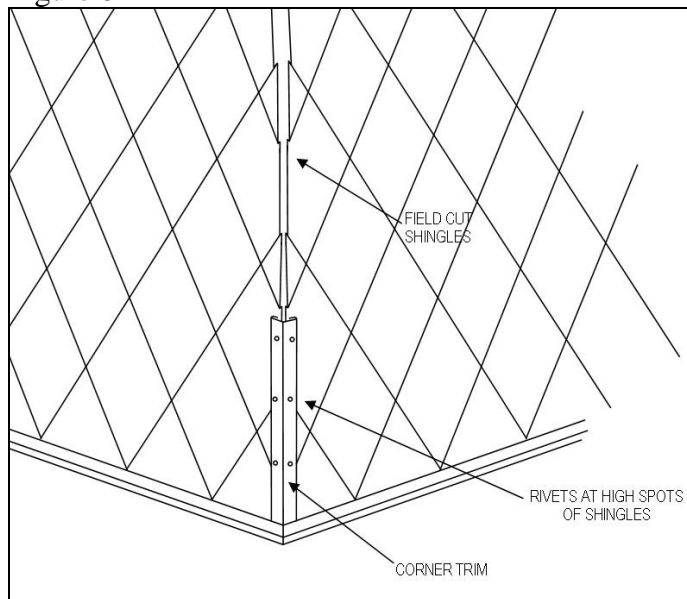

Jamb Condition:

Jamb, head and other transition or termination conditions: field trim shingles following procedures similar to those outlined in the outside corner condition. Reference shop drawing details for trim profiles and attachment procedures.

Cutting Penetrations:

Penetrations will be cut as needed, as work progresses. Verify location and size of penetration, remembering to allow for engagement into clips. . . Mark penetration on the back of the panel and drill

a pilot hole within the penetration, large enough for a jig saw blade. Cut the opening from the back side of the panel using a variable speed jig saw with a plywood cutting blade (Figure 9). Smooth the cut with a single cut metal file.

Figure 9

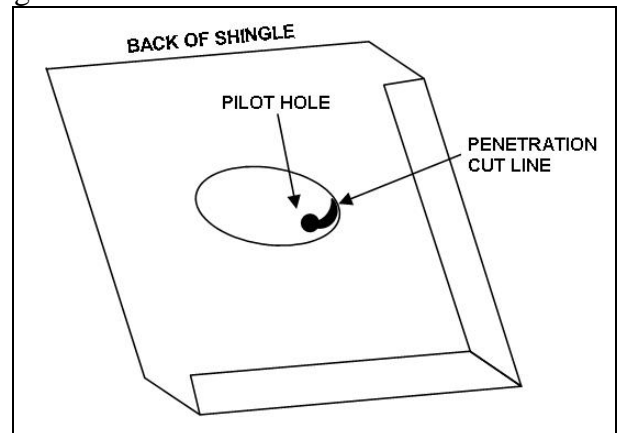

Cleaning Panels:

In most cases, never use anything more than mild detergent and a soft cloth to clean the panels. Rise with clean water immediately afterwards. See panel manufacturer's recommendations for proper cleaning methods.

Clean up:

Keep work areas free of objects that could cause injury or damage to the panels. At the end of each work day, place all trash and debris into the appropriate containers for disposal.

These guidelines are intended to convey the general sequences and procedures. Each application may vary and require specialized procedures. Refer to the project specific details for specialized instruction or contact Metal Design Systems, Inc. phone: 319-362-7454

Revised 3/11/10