

# MDSI Non-Progressive Series 40

## Installation Guidelines



**METAL  
DESIGN  
SYSTEMS**

---

**DESIGNED FOR  
A PERFECT FIT.**

---

Metal Design Systems is pleased to offer an Installer's EDGE training course at our home office in Cedar Rapids, Iowa. This class is offered once a month, free of charge to the installer. If you are interested in attending, please contact MDSI via email at [tech@crmdsi.com](mailto:tech@crmdsi.com).

# Metal Design Systems, Inc.

## SERIES 40

### Installation Guidelines

#### Required Equipment:

##### Forklift:

Typically crates are shipped directly to the job site from our fabrication facility via LTL carrier. This means that the crates will arrive in an enclosed trailer which will require either a dock and a fork lift, or an extended reach forklift in order to unload the crates. The average crate size is 4' x 10', but they can be up to 5' x 16'. Large shipments can be delivered on flat bed trucks if prior arrangements are made.

##### Man-lift/Scaffolding/Ladders:

The terrain, accessibility, quantity of work on each area, and height of work will typically determine the type of lift equipment required to complete each project. The preferred option will usually be an all terrain scissor lift because it offers a larger platform allowing for more work space and fewer moves.

##### Work Table:

You will need a work surface to prep the panels for installation, cut penetrations, or make field modifications. The table should be large enough to safely support the largest panels on the project, and be covered with a long pile carpet to protect the panels from damage. Some installers prefer to build tables on site using the crating materials. This is perfectly acceptable provided they are constructed in a sturdy fashion.

##### Power Tools:

10" or 12" miter saw with 80 tooth non-ferrous metal cutting blade for cutting extrusions; jig saw with plywood cutting blade for cutting penetrations in panels; router with carbide tipped, flat point V-bit; drill and various sized drill bits; screw gun with 5/16" hex head driver and #2 Phillips bit.

##### Hand Tools:

Pop-Rivet gun, rubber mallet, single-cut metal file, countersink bit, hole saw kit for penetrations, caulk gun, utility knife, single edge razor blades, tin snips, flat blade screw driver, tape measure, 4 foot level, torpedo level, (a laser or sight level can be very helpful for layout depending upon the complexity of the project), chalk line, safety glasses, work gloves, and hearing protection.

##### Supplies:

Always have an ample supply of fasteners in various sizes; plastic horseshoe shims in 1/4", 1/8", and 1/16" thicknesses; silicone sealant in the appropriate color; waterproof tarps to cover the crates; and shop rags.

##### Crew Size:

A crew size of three typically works best in most cases. This allows for two in the lift, handling and installing the panels on the wall, and one on the ground prepping panels, cutting and drilling extrusions, and general ground support.

##### Unloading:

Prior to unloading the crates from the delivery truck, inspect the crates for damage.

**Note: Report any damage to the carrier and note the damage on the shipping tickets. The receiver must make all claims for damage through the carrier upon receipt. Metal Design Systems, Inc. is not responsible for any damage after the product leaves the factory.**

Unload the material one crate at a time, knowing and following all safety rules. Use the proper equipment for the weight being unloaded. If unloading with an overhead crane, use a spreader bar and nylon sling. Do not "choke" the crates. Do not attempt to lift the crates by hand, drag, drop, or stack the crates.

### Inspection and Inventory:

Shipping damage should be noted on the Bill of Lading and then reported to Metal Design Systems, Inc.

**Note: The customer is responsible for filing a claim for freight damage with the shipping company within 24 hours of receipt. Failure to do so may result in forfeiture of the right to receive corrective action.**

After verifying the condition of the product, inventory the panels and miscellaneous items and compare against the packing slip to ensure all material is received.

**Note: Notify Metal Design Systems, Inc. immediately if the quantities received do not match the packing list. Failure to do so may result in forfeiture of the right to receive corrective action.**

### Storage:

Store crates in a clean dry place. If the crates are to be stored outside, cover the crates to protect from the elements and ventilate to minimize heat build up (Figure 1). At the end of each work day, place loose panels back into the open crates, secure the panels, and cover the crate.

Figure 1

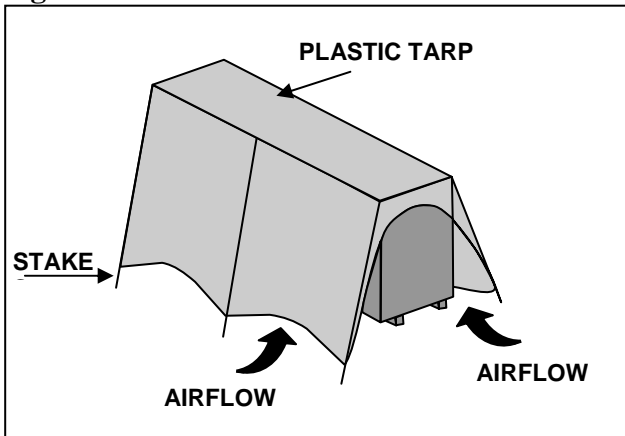

### Shake Out:

Crate #1 will have a set of shop drawings revised to reflect field measurements and indicating panel part numbers and locations.

Each crate will have a packing slip indicating the part numbers and quantities of the panels enclosed. At this time it may be beneficial to boldly write the contents of each crate on the outside for future reference. If possible, strategically place each crate in a location convenient to the final destination of its contents.

### Handling Individual Panels:

When removing panels from the crate, always take care to lift and clear other panels and sidewalls of the crate (Figure 2). Never slide or drag panels out of its location. When carrying a panel, always carry it "on edge" and never flat (Figure 3). Always be aware of your surroundings and take special care when handling panels that have intermediate routs or panels that have welded connections. Do not place the panels in any position that will cause the panel face or edges to come into contact with any surface that will cause damage to the protective film or panel finish. The protective film is designed to prevent minor abrasions. Extreme care should still be taken to avoid dents and scratches.

Figure 2

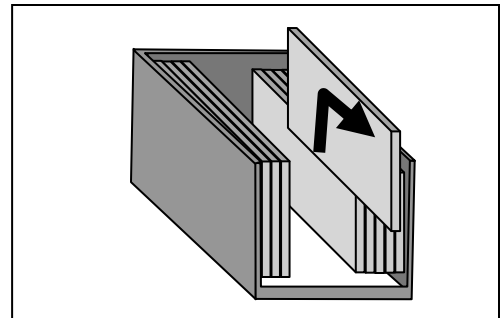
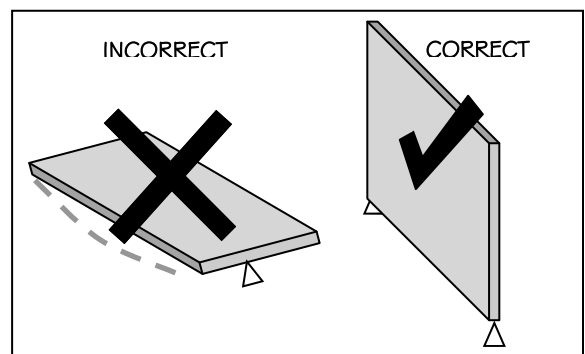

Figure 3



### Substrate/ Job Inspection:

Inspect the area that is to receive the panels to ensure that all work is complete and satisfactory. All substrates, weather barriers, penetrations, doors, windows, and any other adjacent materials should be in place and cleaned prior to proceeding with panel installation.

**Note: Acid wash used for cleaning masonry will cause permanent damage to the panels.**

Ensure that all surfaces are plumb, level, square, true, dry, and free from defects. Do not begin installation until all unsatisfactory conditions have been corrected.

### Layout:

Reference the revised shop drawings and locate key components for panel system alignment (i.e. windows, doors, window mullions, or other items that are critical to joint locations) and begin layout from these locations. Snap chalk lines at the center of each panel joint making sure that all lines are level and plumb (**Figure 4**). This will help to control panel gain or loss over a long run. If the panel system is to be installed over a gypsum board substrate, locate all framing members to ensure that all fasteners engage a structurally sound member.

**Figure 4**

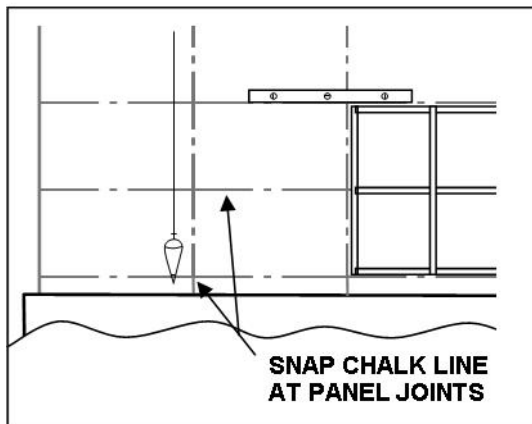

### Installing Flashing and Weather Barrier:

Install flashing using standard sheet metal practices and procedures, ensuring that all joints and seams are weather lapped and sealed. For weather barrier, follow manufactures written instructions for proper installation. Integrate weather barrier and flashing to allow proper drainage of any moisture that may enter or accumulate within the panel system.

### Installing Panels

#### Metal Design Systems Series 40

##### Setting Up:

Locate work table and miter saw in a safe and convenient location relative to the installation area. Locate the “Perimeter” (Part # 4001) and “Intermediate” (Part # 4002) aluminum extrusions and the plastic wedge extrusion (Part # 4003). Cut one length of the plastic wedge extrusion into 6” long pieces. These will be used for temporarily securing the aluminum extrusion to the panel and for panel joint spacing.

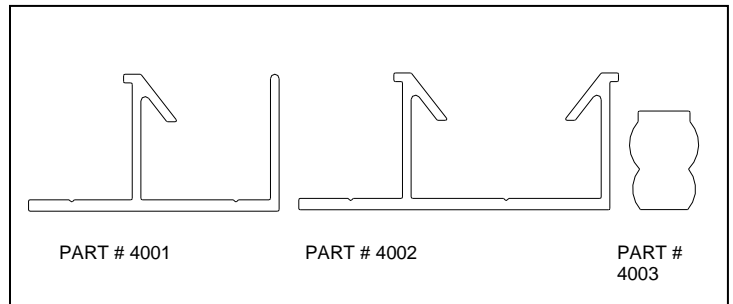

##### Panel Prep:

Locate the panel that is to be installed first, remove it from the crate and inspect again for damage. Place the panel on the work table and peel back the protective film from the panel return legs. Trim off the loose film using a single edge razor blade taking care not to scratch the panel finish (**Figure 5**). If penetrations need to be cut in the panel it should be done so at this time.

**Figure 5**

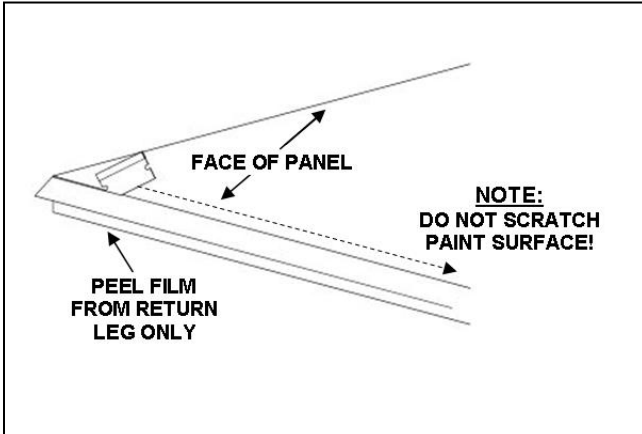

**Cutting Penetrations:**

Verify location and size of penetration remembering to allow for engagement into anchor extrusions. Mark penetration on the back of the panel and drill a pilot hole within the penetration large enough for a jig saw blade. Cut the opening from the back side of the panel using a variable speed jig saw with a plywood cutting blade (Figure 6). Smooth the cut with a single cut metal file.

**Figure 6**

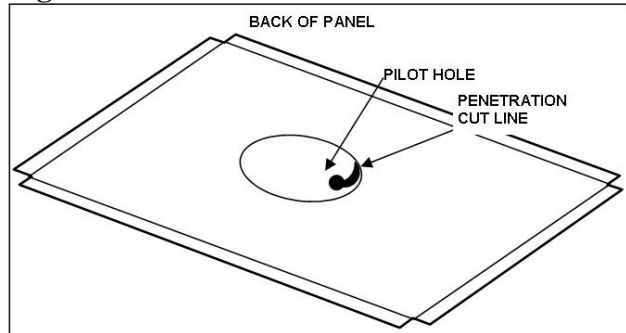

**Note:** If the object penetrating the panel does not have a weatherproof escutcheon, you will need to caulk around the object penetrating. Therefore the panel will require a return leg around the opening to caulk to. Cut opening in the same manner as above except that the opening should be 1" smaller than the object penetrating the panel. Using the router and the v-bit, rout grooves around the opening 1" away from the opening (Figure 7).

**Figure 7**

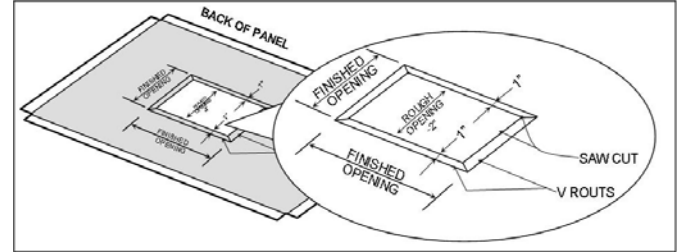

Use a fence to protect the good side of the panel and allow a clean straight rout (Figure 8).

**Figure 8**

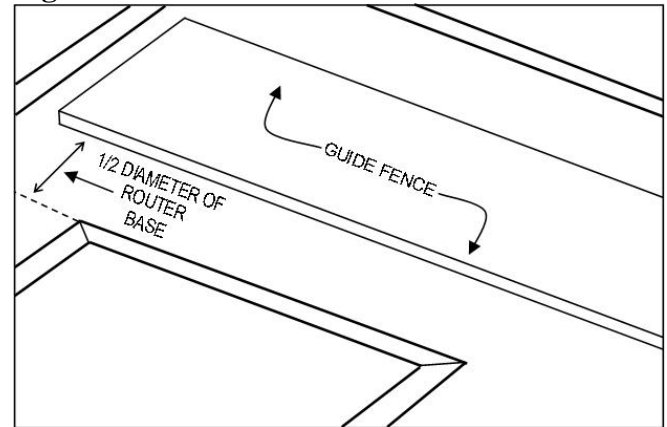

Two sided tape works well to temporarily secure the fence to the back of the panel (Figure 9).

**Figure 9**

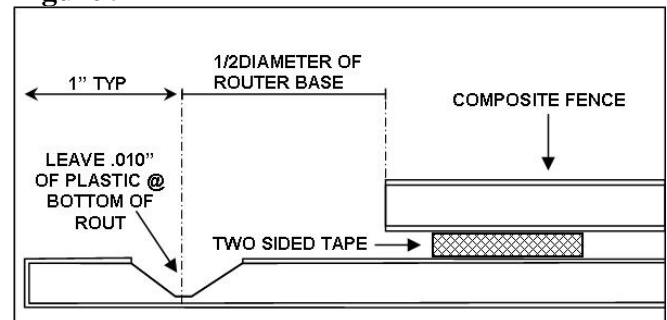

Saw cut the returns at the inside corners taking care not to cut past the v-rout (Figure 10).

**Figure 10**

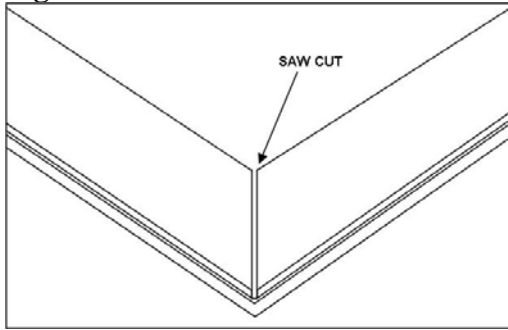

Back up the returns at the inside corners using a small piece of aluminum sheet bent to an angle. Pop-rivet or screw into place (**Figure 11**).

**Figure 11**

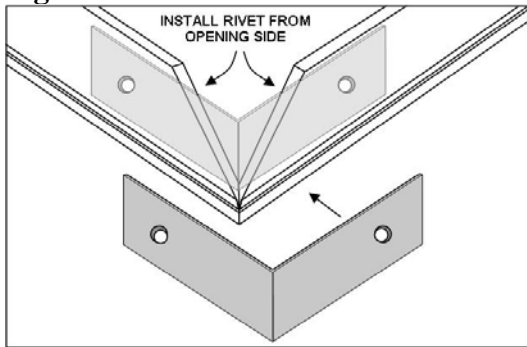

Back up the angle with butyl sealant (**Figure 12**).

**Figure 12**

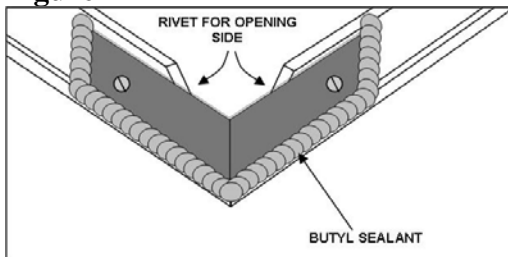

**Cutting Perimeter Extrusions:**

Perimeter extrusion (Part #4001) will be fastened to the wall prior to setting the panel. Locate the edge of the panel that abuts another wall finish (i.e. window, brick wall, sill, etc.) Cut a length of the perimeter extrusion approximately 3” shorter than this panel edge.

This must be done for each panel edge that is adjacent to other finishes. (**Figure 13**)

**Figure 13**

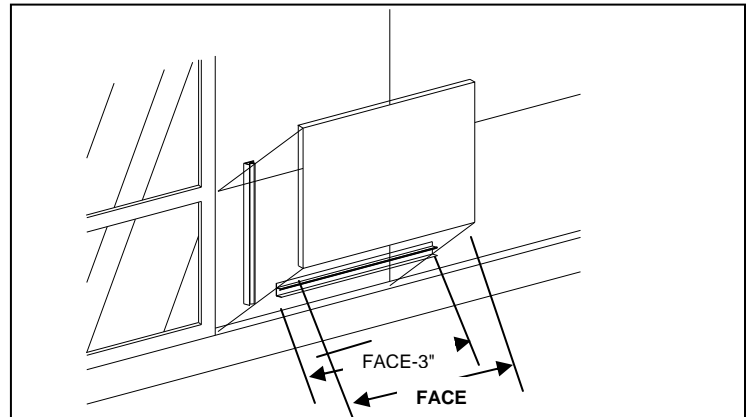

**Note: The perimeter extrusion (#4001) can be installed in a continuous fashion. However, notches must be made in the extrusion where intersecting joints occur (Figure 14).**

**Figure 14**

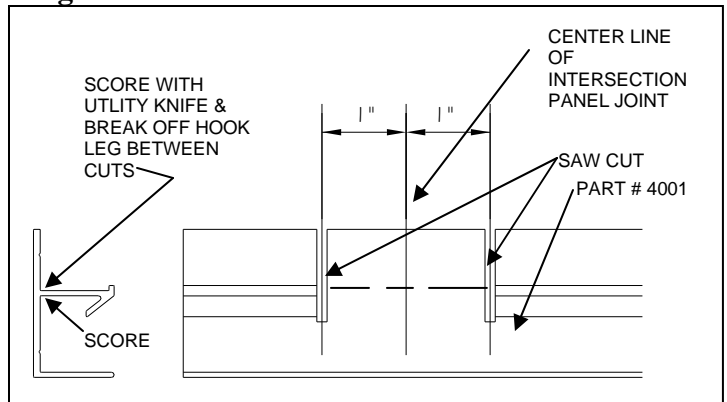

**Installing Perimeter Extrusions:**

Align the center alignment mark on the extrusion with the chalk line previously laid out on the wall and approximately centered between the edges of the panel. Drill clear holes in the extrusion at the witness groove that will align with the structural support framing. Fasten the extrusion to the wall using the appropriate fasteners and spacing (**Figure 15**). Metal Design Systems, Inc. recommends a minimum #12 stainless steel tek or wood screws (depending upon the substrate) spaced a

maximum of 16" on center. If system is applied over a gypsum board substrate, ensure that the fasteners are located and of sufficient length to properly engage a structural member. Wood screws require a minimum of 1" penetration into the wood and tek screws require a minimum of three full threads extending past the back side of the metal.

**Figure 15**

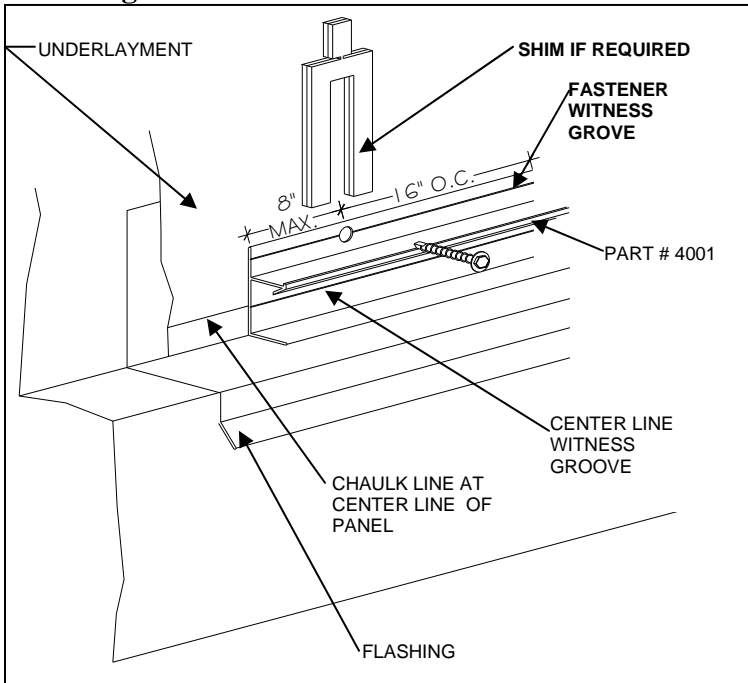

**Sealing Inside Corners of Panels:**

Prior to installing the panels on the wall, the corners of each panel must be sealed. Using butyl tube sealant, squeeze a bead into the v-routs and mitered corner approximately 1" in all three directions (Figure 16).

**Figure 16**

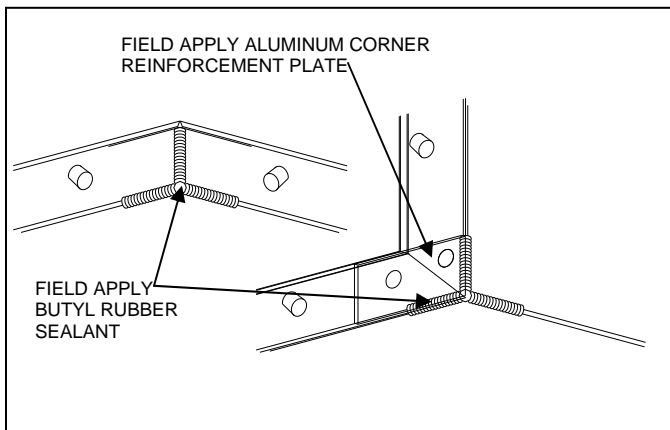

**Attaching Intermediate Extrusions to Panel:**

Determine the edges of the panel that will require the "Intermediate" #4002 extrusions. This is the edge of the panel that will have an adjoining panel. Cut a length of the extrusion approximately 3" shorter than the edge of the panel. Do this for each edge that will have an adjoining panel. With the panel face down on the carpeted table, bring the edge of the panel that is to receive the "Intermediate" extrusion to the edge of the table. Engage the "Intermediate" extrusion over the pins in the return leg of the panel, making sure that the anchor flange of the extrusion is on the outboard edge (Figure 17).

**Figure 17**

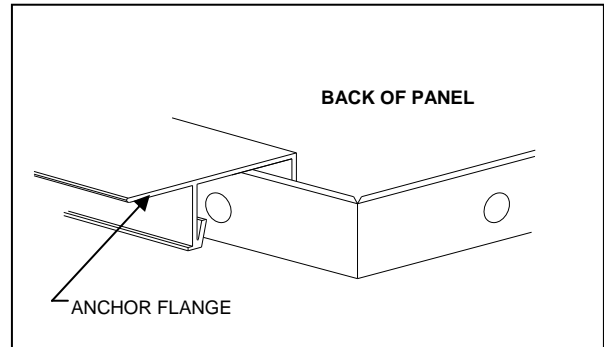

Locate the extrusion so that it is approximately 1 1/2" short of each end of the panel or centered on the length. Using one of the previously cut 6" lengths of plastic wedge, insert one end between the panel return and the hook of the aluminum extrusion and twist 90 degrees to lock the extrusion onto the panel (Figure 18).

**Figure 18**

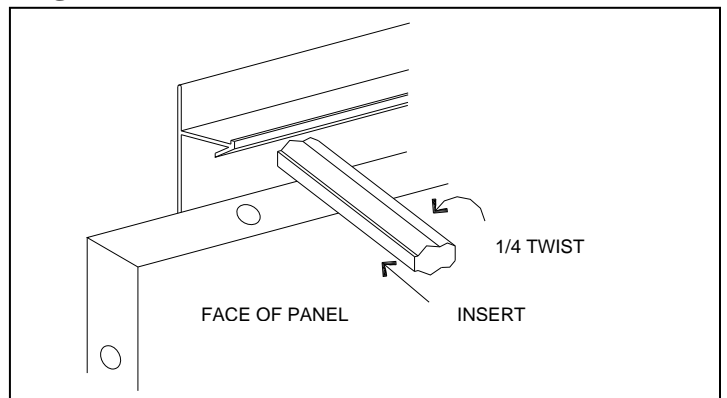

Insert the wedges about 3' on center but at least two on each edge. Do this to each edge that will have an adjoining panel.

**Setting Panels:**

Engage the edge of the panel over the previously installed "Perimeter" extrusion, making sure the pins have engaged over the hook of the extrusion (**Figure 19**).

**Figure 19**

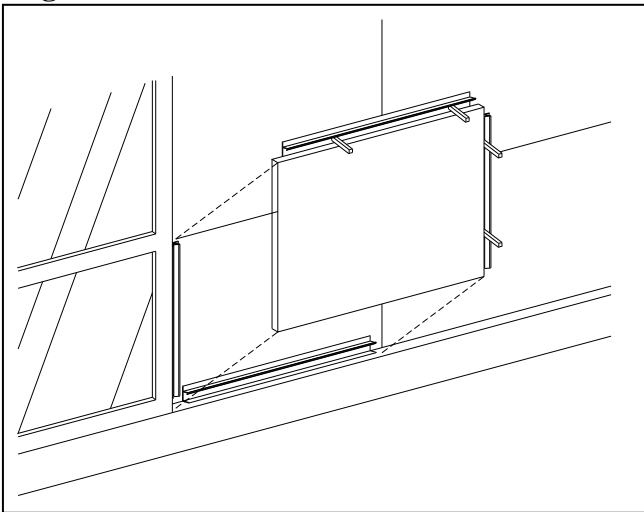

Loosely adjust the panel so that the alignment marks on the extrusion match up to the chalk lines on the wall. Using more of the 6" long wedges, insert them into the joint of the perimeter extrusion and the panel. These will be inserted to space the 1/2" wide joint so they will NOT be twisted (**Figure 20**).

**Figure 20**

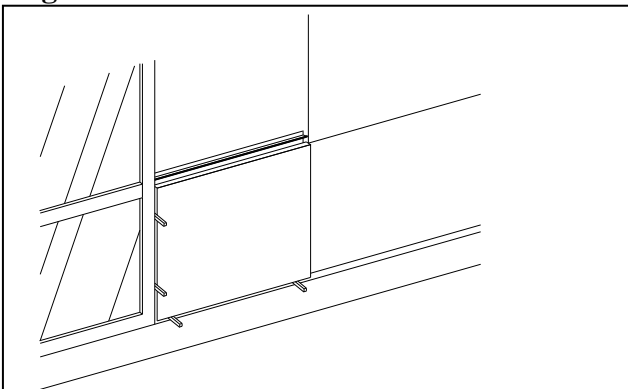

Make final adjustments to align the centerline marks and the layout lines and fasten extrusions to the wall. Drill clear holes in the extrusion at the witness groove that will align with the structural support framing. Fasten the extrusion to the wall using the appropriate fasteners and spacing (**Figure 15**). Metal Design Systems, Inc. recommends a minimum #12 stainless steel self drilling or wood screws (depending upon the substrate) spaced a maximum of 16" on center. If system is applied over a gypsum board substrate, ensure the fasteners are located and of sufficient length to properly engage a structural member. Wood screws require a minimum of 1" penetration into the wood and self drilling screws require a minimum of three full threads extending past the back side of the metal. Shim extrusions as required to ensure a flat and true panel face. After the extrusion has been secured to the wall, the temporary wedges that secured the extrusion to the panel can be removed. Repeat steps for setting perimeter extrusions, prepping panels for install, temporarily securing field extrusions to leading edges of panels, and fastening extrusions to the wall until complete (**Figure 21**).

**Figure 21**

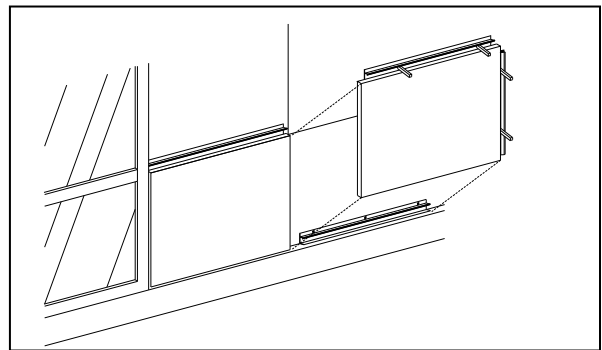

Prior to the end of each day, make sure all panels are secure so that none of the panels can become disengaged.

**Installing Joint Wedge #4003:**

The wedges must be installed with a sufficient amount of gap to allow for thermal expansion. This would be a 1" gap where parts are butted end to end in 10' lengths and a 1/2" gap at the "T" intersections.

Insert the wedge into all panel joints with widest portion and crown side towards the face of the panel (Figure 22).

**Figure 22**

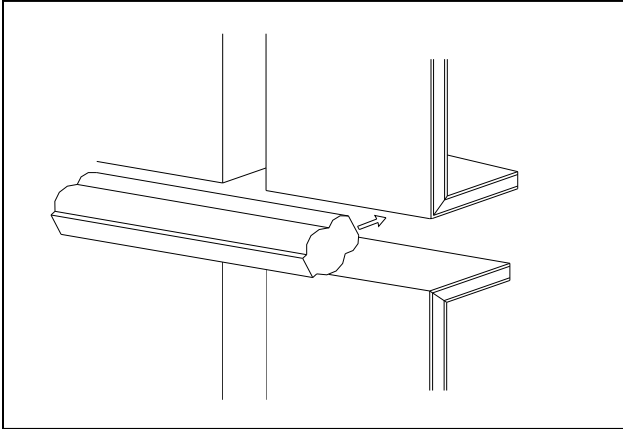

Follow the spacing recommendations above. The wedge should be started by hand and inserted as far as possible with hand pressure alone. Drive the wedge into the joint until it bottoms out on the aluminum extrusion by using a 6" length of the same wedge, holding it perpendicular to the joint and tapping with a rubber mallet. Fill gaps between wedge with small pieces of open cell backer rod. Metal Design Systems, Inc. recommends that the caulking be applied in the joints shortly after installation of the wedge. If caulking can not be applied within a reasonable time and the wedge will be left exposed to the sun, cut the 10' long parts to 5' and allow a 1/2" gap at all intersections. Install one #8 bugle head self drilling screw in the center of each part to keep it from walking.

### **Removing Protective Film:**

The protective film should be removed immediately after final installation of the panel or at least at the end of each work day. Peel the film back against itself on the same plane as the panel face.

**Note: The film removal process may cause a static charge to build. To reduce the possibility of static shock, ground yourself**

**against the portion of the panel with the film removed.**

**Note: Panels with film left exposed to UV for extended periods of time may become difficult to remove. Panels with film partially removed and left exposed to dirt and UV rays may become discolored.**

### **Caulking the Panel Joints:**

Use clean release masking tape to mask off the panel face along each panel joint. Clean the panel joints within 1 to 2 hours of when the sealant will be applied. If required for compatibility, apply sealant primer to the return legs of the panel.

**Note: Follow sealant manufacturers' cleaning, priming and installation instructions.**

Carefully fill panel joints with sealant making sure to avoid skips and bubbles. Tool caulking to ensure full contact with joint sidewalls and to leave a smooth concaved surface (Figure 23).

**Figure 23**

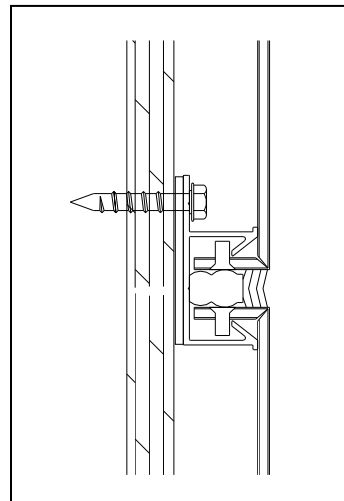

**Note: Reference Metal Design Systems, Inc.'s recommended sealants on the cover sheet of your project shop drawings.**

Remove masking taking care to not allow wet sealant to come into contact with the panel face or any other finished surface.

### **Cleaning Panels:**

In most cases, never use anything more than mild detergent and a soft cloth to clean the panels. Rinse with clean water immediately afterwards. See panel manufacturer's recommendations for proper cleaning methods.

### **Clean Up:**

Keep work areas free of objects that could cause injury or damage to the panels. At the end of each work day, place all trash and debris into the appropriate containers for disposal.

**These guidelines are intended to convey the general sequences and procedures. Each application may vary and require specialized procedures. Refer to the project specific details for specialized instruction or contact Metal Design Systems, Inc. phone: 319-362-7454**

**Revised 3/11/10**