

MDSI Rear Ventilated Rainscreen

Series 20

Installation Guidelines



**METAL
DESIGN
SYSTEMS**

**DESIGNED FOR
A PERFECT FIT.**

Metal Design Systems is pleased to offer an Installer's EDGE training course at our home office in Cedar Rapids, Iowa. This class is offered once a month free of charge to the installer. If you are interested in attending or would like more information, please contact MDSI via email at tech@crmdsi.com.

Metal Design Systems, Inc.

SERIES 20

Installation Guidelines

Required Equipment:

Forklift:

Typically crates are shipped directly to the job site from our fabrication facility via LTL carrier. This means that the crates will arrive in an enclosed trailer which will require either a dock and a fork lift or an extended reach forklift in order to unload the crates. The average crate size is 4' x 10', but they can be up to 5' x 16'. Large shipments can be delivered on flat bed trucks if prior arrangements are made.

Man-lift/Scaffolding/Ladders:

The terrain, accessibility, quantity of work on each area, and height of work will typically determine the type of lift equipment required to complete each project. The preferred option will usually be an all terrain scissor lift because they offer a larger platform allowing for more work space and fewer moves.

Work Table:

You will need a work surface to prep the panels for installation, cut penetrations or make field modifications. The table should be large enough to safely support the largest panels on the project and be covered with a long pile carpet to protect the panels from damage. Some installers prefer to build tables on site using the crating materials. This is perfectly acceptable provided that they are constructed in a sturdy fashion.

Power Tools:

10" or 12" miter saw with 80 tooth non-ferrous metal cutting blade for cutting extrusions; jig saw with plywood cutting blade for cutting penetrations in panels; router with carbide tipped, flat point V-bit; drill and various sized drill bits; screw gun with 5/16" hex head driver and #2 Phillips bit.

Hand Tools:

Pop-Rivet gun; rubber mallet; single-cut metal file; countersink bit; hole saw kit for penetrations; caulk gun; utility knife; single edge razor blades; tin snips; flat blade screw driver; tape measure; 4 foot level; torpedo level; (a laser or sight level can be very helpful for layout depending upon the complexity of the project); chalk line; safety glasses work gloves and hearing protection.

Supplies:

Always have an ample supply of fasteners in various sizes; plastic horseshoe shims in 1/4", 1/8" and 1/16" thicknesses; silicone sealant in the appropriate color; waterproof tarps to cover the crates and shop rags.

Crew Size:

A crew size of three typically works best in most cases. This allows for two in the lift handling and installing the panels on the wall and one on the ground prepping panels, cutting and drilling extrusions, and for general ground support.

Unloading:

Prior to unloading the crates from the delivery truck, inspect the crates for damage.

Note: Report any damage to the carrier and note the damage on the shipping tickets. The receiver must make all claims for damage through the carrier upon receipt. Metal Design Systems, Inc. is not responsible for any damage after the product leaves the factory.

Unload the material one crate at a time, know and follow all safety rules. Use the proper equipment for the weight being unloaded. If unloading with an overhead crane, use a spreader bar and nylon slings, do not "choke" the crates. Do not attempt to lift the crates by hand, drag, drop or stack the crates.

Inspection and Inventory:

Shipping damage should be noted on the Bill of Lading and then reported to Metal Design Systems.

Note: The customer is responsible for filing a claim for freight damage with the shipping company within 24 hours of receipt. Failure to do so, may result in forfeiture of the right to receive corrective action.

After verifying the condition of the product, inventory the panels and miscellaneous items and compare against the packing slip to ensure that all material is received.

Note: Notify Metal Design Systems immediately if the quantities received do not match the packing list. Failure to do so, may result in forfeiture of the right to receive corrective action.

Storage:

Store crates in a clean dry place. If the crates are to be stored outside, cover the crates to protect from the elements and ventilate to minimize heat build up (**Figure 1**). At the end of each work day, place loose panels back into the open crates, secure the panels, and cover the crate.

Figure 1

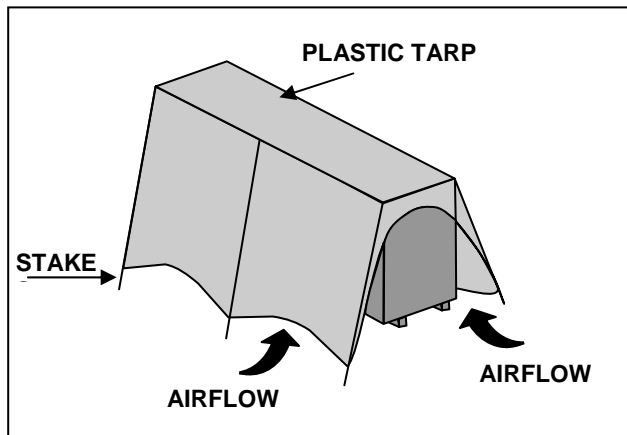

Shake Out:

Crate #1 will have a set of shop drawings revised to reflect field measurements and indicating panel part numbers and locations. Each crate will have a packing slip indicating the part numbers and quantities of the panels enclosed. At this time it may be beneficial to boldly write the contents of each crate on the outside for future reference. If possible, strategically place each crate in a

location convenient to the final destination of its contents.

Handling Individual Panels:

When removing panels from the crate, always take care to lift and clear other panels and sidewalls of the crate (**Figure 2**). Never slide or drag panels out of its location. When carrying a panel, always carry it “on edge” and never flat (**Figure 3**). Always be aware of your surroundings and take special care when handling panels that have intermediate routs or panels that have welded connections. Do not place the panels in any position that will cause the panel face or edges to come into contact with any surface that will cause damage to the protective film or panel finish. The protective film is designed to prevent minor abrasions. Extreme care should still be taken to avoid dents and scratches.

Figure 2

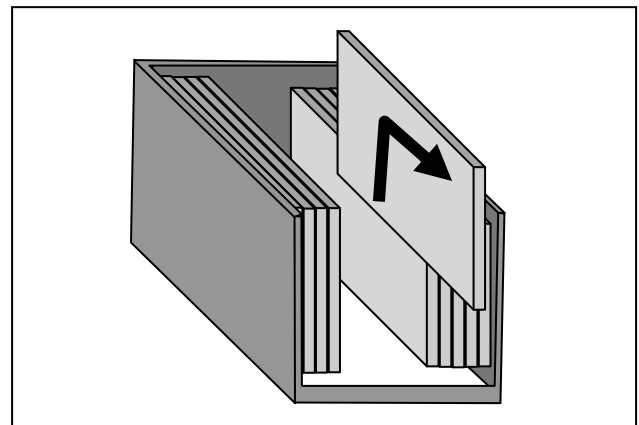
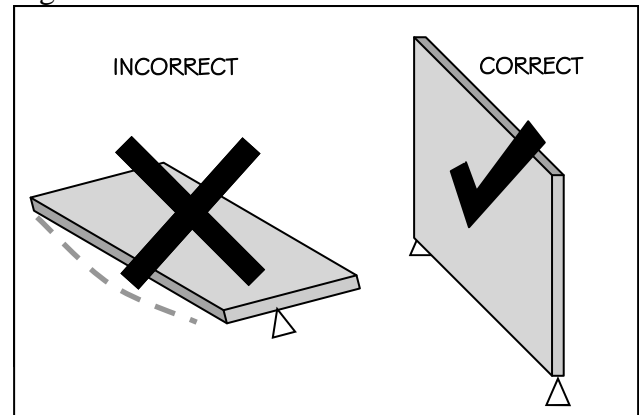

Figure 3



Substrate/Job Inspection:

Inspect the area that is to receive the panels to ensure that all work is complete and satisfactory. All substrates, weather barriers, penetrations, doors, windows, and any other adjacent materials should be in place and cleaned prior to proceeding with panel installation.

Note: Acid wash used for cleaning masonry will cause permanent damage to the panels.

Ensure that all surfaces are plumb, level, square, true, dry and free from defects. Do not begin installation until all unsatisfactory conditions have been corrected.

Layout:

Reference the revised shop drawings and locate key components for panel system alignment (i.e. windows, doors, window mullions or other items that are critical to joint locations) and begin layout from these locations. Snap chalk lines at the center of each panel joint making sure that all lines are level and plumb (**Figure 4**). This will help to control panel gain or loss over a long run. If the panel system is to be installed over a gypsum board substrate, locate all framing members to ensure that all fasteners engage a structurally sound member.

Figure 4

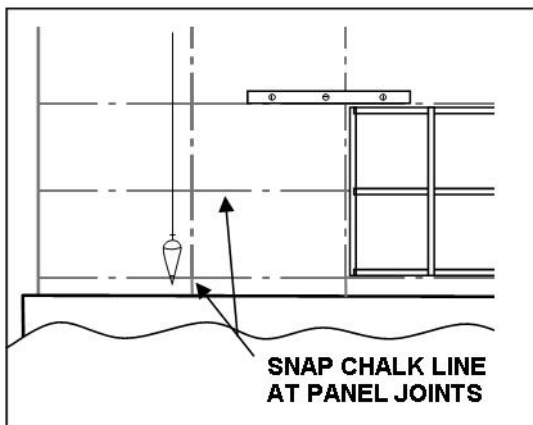

Installing Flashing & Weather Barrier:

Install flashing using standard sheet metal practices and procedures, ensuring that all joints and seams are weather lapped and sealed. For

weather barrier, follow manufacture's written instructions for proper installation. Integrate weather barrier and flashing to allow proper drainage of any moisture that may enter or accumulate within the panel system.

Installing Panels Metal Design Systems Series 20:

Setting up:

Locate work table and miter saw in a safe and convenient location relative to the installation area. Locate the "J" (Part # 2001) and "H" (Series 30 Part # 3001) aluminum extrusions and the 1" and 1 5/8" wide composite joint fillers. 1" wide fillers will be used at panel to other material joints, and 1 5/8" wide fillers will be used at 1/2" wide panel to panel joints. 1 7/8" wide fillers will be used at 3/4" wide panel to panel joints.

Extrusion Prep:

Begin by drilling clear holes in the starter "J" extrusion. Holes should be located in the "witness groove" and to align with the structural support and a maximum of 6" from the end and 16" on center (**Figure 5**). The "J" starters are typically preinstalled to the wall and in continuous lengths.

Figure 5

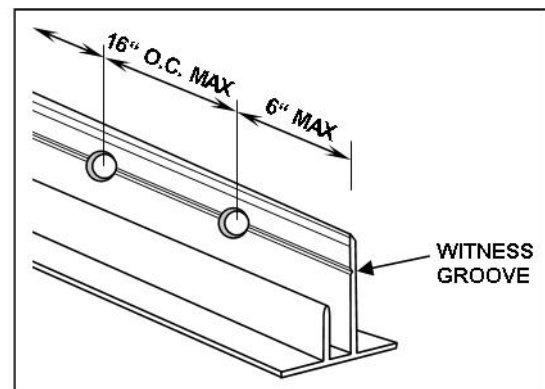

Factory supplied "H" extrusions are sent in 4" lengths. They will have two holes pre-drilled. You may use only one of the holes if the panels are going over a gypsum board substrate and use both holes if over a plywood substrate (**Figure 6**).

Figure 6

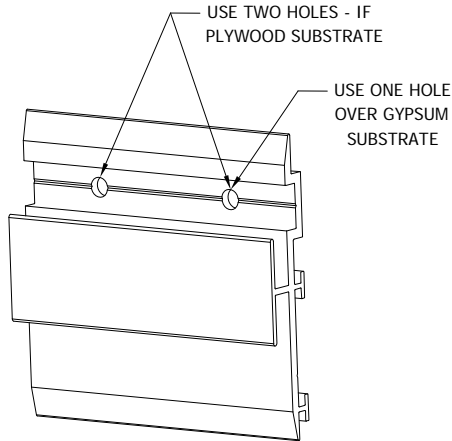

Panel Prep:

Remove panel from crate and inspect again for damage. Make sure weep holes are free from obstructions. If penetrations need to be cut in the panel it should be done so at this time.

Cutting Penetrations:

Verify location and size of penetration, remembering to allow for engagement into anchor extrusions. Mark penetration on the back of the panel and drill a pilot hole within the penetration, large enough for a jig saw blade. Cut the opening from the back side of the panel using a variable speed jig saw with a plywood cutting blade (Figure 7). Smooth the cut with a single cut metal file.

Figure 7

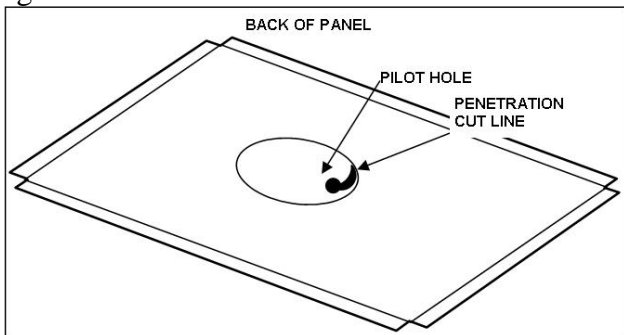

Note: If the object penetrating the panel does not have a weatherproof escutcheon, you will need to caulk around the object penetrating. Therefore the panel will require a return leg around the opening to caulk to. Cut opening in the same manner as above except that the opening should be 1"

smaller than the object penetrating the panel. Using the router and the v-bit, rout grooves around the opening 1" away from the opening (Figure 8).

Figure 8

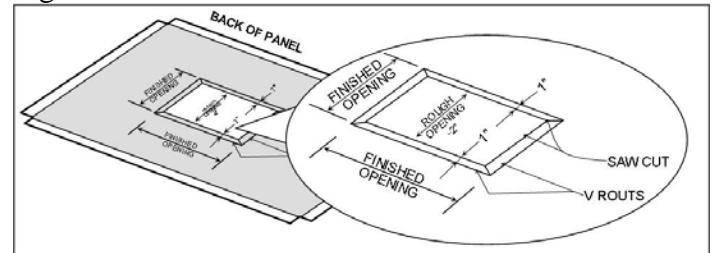

Use a fence to protect the good side of the panel and allow a clean straight rout (Figure 9).

Figure 9

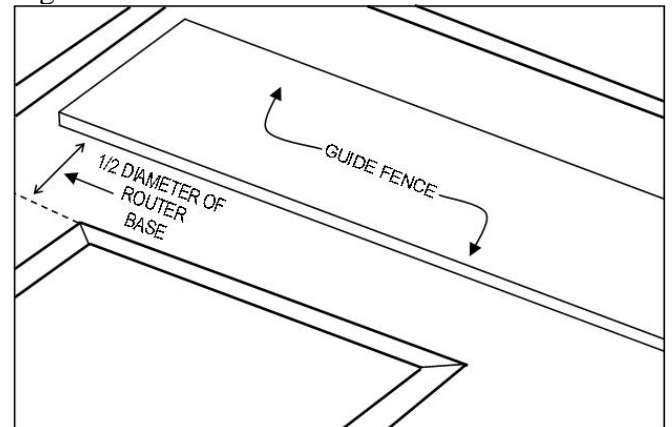

Two sided tape works well to temporarily secure the fence to the back of the panel (Figure 10).

Figure 10

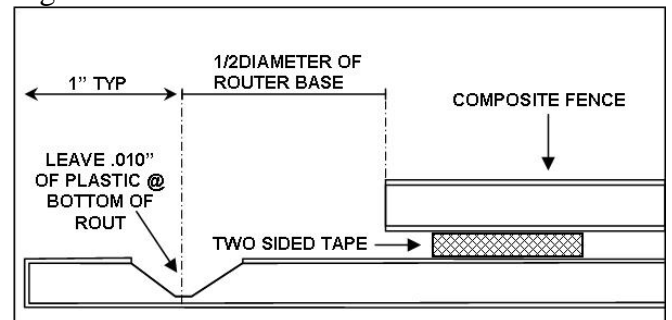

Saw cut the returns at the inside corners taking care not to cut past the v-rout (**Figure 11**).

Figure 11

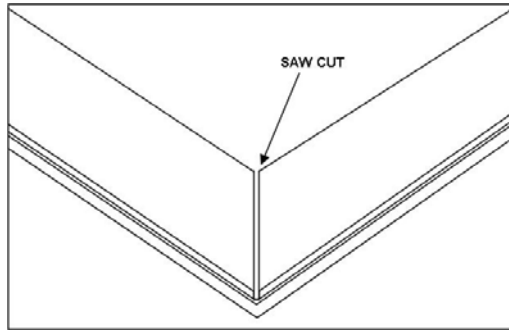

Back up the returns at the inside corners using a small piece of aluminum sheet bent to an angle. Pop-riquet or screw into place (**Figure 12**).

Figure 12

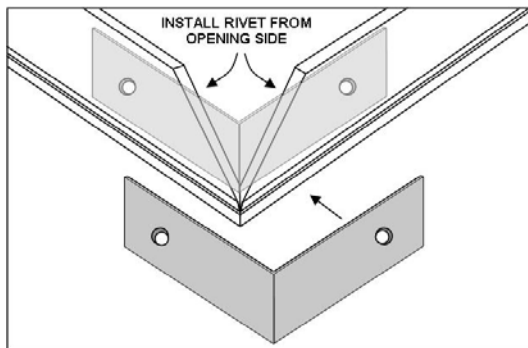

Back up the angle with butyl sealant (**Figure 13**).

Figure 13

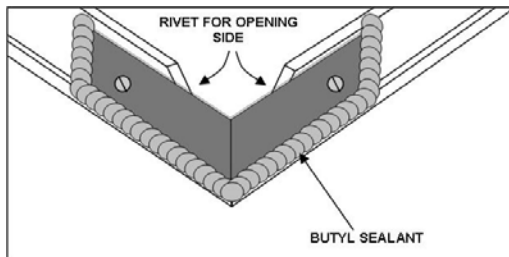

Setting Starter “J” Extrusions:

Prior to installing starter “J” channel extrusions, pre-drill 5/16” diameter weep holes as shown in the **Figure 14** at 48” O.C. maximum. Typically the “J” extrusion will be set 1/4” off the adjacent materials. This may vary depending upon the results of the layout. Fasten the extrusion to the wall using the appropriate fasteners and spacing. Metal Design Systems, Inc. recommends a

minimum #12 stainless steel tek or wood screws (depending upon the substrate) spaced a maximum of 16” on center. If system is applied over a gypsum board substrate, ensure that the fasteners are located and of sufficient length to properly engage a structural member. Wood screws require a minimum of 1” penetration into the wood and tek screws require a minimum of three full threads extending past the back side of the metal. Before setting the panels, make sure all sill splice conditions are properly sealed (**Figure 14**) with Part #2005 sill splice, weep holes are drilled, baffles installed and all end conditions are properly sealed or dammed with butyl rubber sealant.

Figure 14

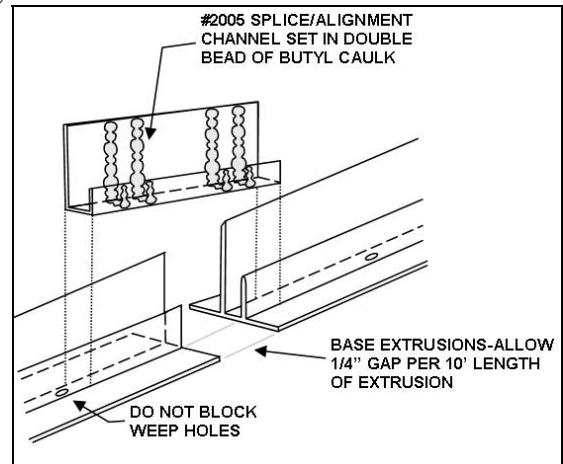

Setting panels:

Engage perimeter extrusion of the panel into the “J” extrusion and adjust panel to align with layout lines (**Figure 15**).

Figure 15

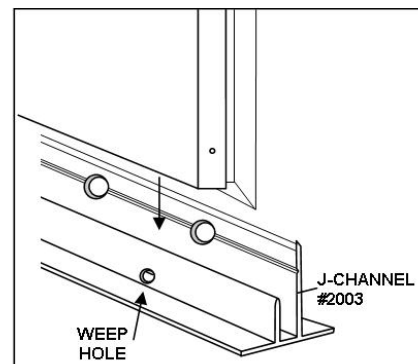

Slip “H” extrusion clips onto the perimeter extrusion on the top edge of the panel making sure the pre-drilled holes are still visible (**Figure 16**).

Figure 16

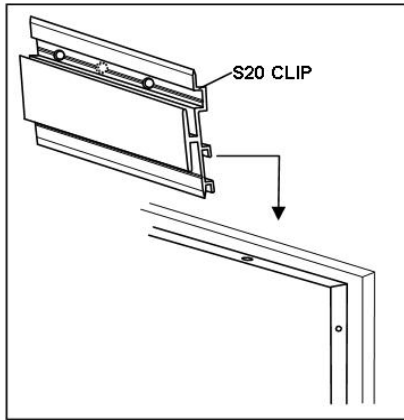

Slide the clips to approximately 16” spacing or one clip over each stud. Start a fastener in each clip but do not tighten. Double check that panel is level and plumb. If shims are required to plumb face of panel, pull panel and “H” clips away from wall and drop the appropriate size plastic horseshoe shim over the fastener and tighten (**Figure 17**).

Figure 17

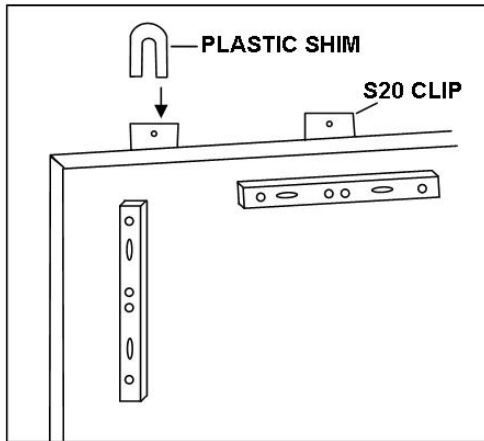

Repeat the process for the vertical edges of the panel. Slide a length of a 1” wide joint filler into the filler pocket of the perimeter extrusion of the panel over the “J” starter extrusions. The protective film should always be removed from the filler prior to placing them.

Set next panel into “J” and shift into the mating “H” of the previously set panel. Again, align this

panel with the layout lines, set “H” clips and double check level and plumb (**Figure 18**).

Figure 18

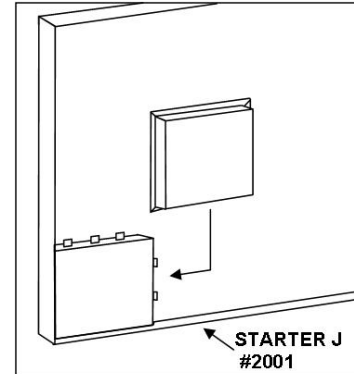

Cut a 1 5/8” wide joint filler to the appropriate length (vertical panel face dimension – 1-1/8”) and drop into the filler pockets of the mating panels (**Figure 19**).

Figure 19

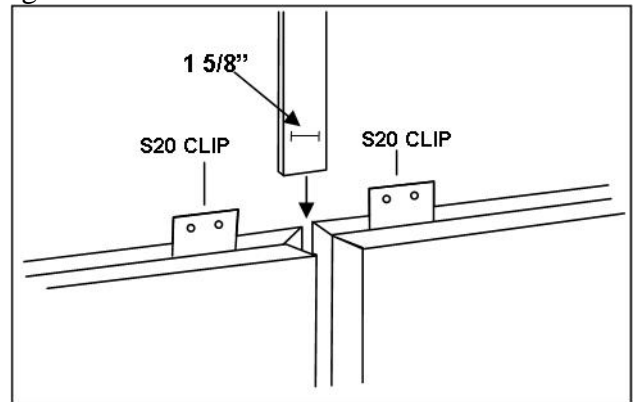

Typically horizontal fillers will carry through continuously and verticals will be cut to length to allow the horizontal to pass through (**Figure 20**).

Figure 20

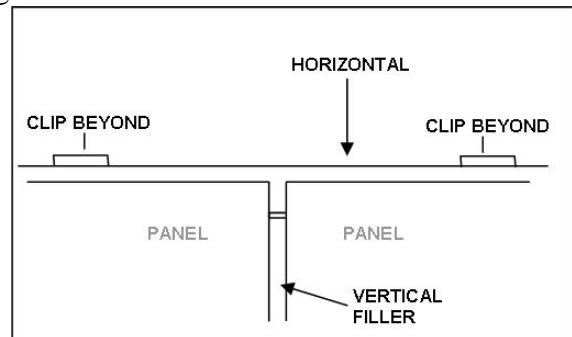

The panels can be installed either by progressing horizontally or vertically. Continue this process until all panels are installed.

Some conditions will require alternative methods of attaching the panels to the substrate and may require that perimeter conditions be caulked with silicone in lieu of using the joint filler. Contact Metal Design Systems for special details.

Note: When caulking perimeter conditions, take extra care not to block weep passages.

Contractors Option

Series 20 “H” extrusion clips (Part #2002) can be pre-attached to wall panel’s perimeter extrusion. Pre-drill a clear hole at the witness groove on the back of the clip. Attach clip to panel extrusion with a 3/4”-1” screw (**Figure 21**).

Figure 21

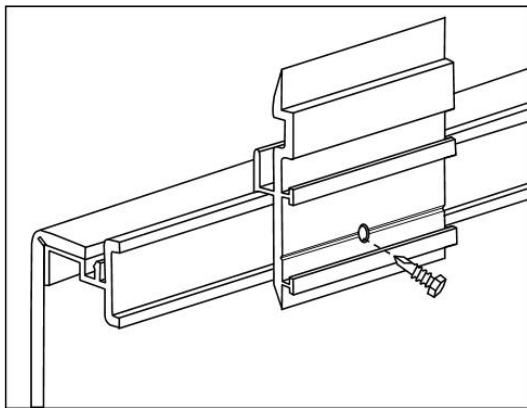

Removing Protective Film:

The protective film should be removed immediately after final installation of the panel or at least at the end of each work day. Peel the film back against itself on the same plane as the panel face.

Note: The film removal process may cause a static charge to build. To reduce the possibility of static shock, ground yourself against the portion of the panel with the film removed.

Note: Panels with film left exposed to UV for extended periods of time may become difficult to remove. Panels with film partially removed and left exposed to UV may become discolored.

Cleaning Panels:

In most cases, never use anything more than mild detergent and a soft cloth to clean the panels. Rise with clean water immediately afterwards. See panel manufacturer’s recommendations for proper cleaning methods.

Clean up:

Keep work areas free of objects that could cause injury or damage to the panels. At the end of each work day, place all trash and debris into the appropriate containers for disposal.

These guidelines are intended to convey the general sequences and procedures. Each application may vary and require specialized procedures. Refer to the project specific details for specialized instruction or contact Metal Design Systems, Inc. phone: 319-362-7454

Revised 3/11/10