

MDSI Glazed Joint Panel Series 10

Installation Guidelines



**METAL
DESIGN
SYSTEMS**

**DESIGNED FOR
A PERFECT FIT.**

Metal Design Systems is pleased to offer an Installer's EDGE training course at our home office in Cedar Rapids, Iowa. This class is offered once a month, free of charge to the installer. If you are interested in attending, please contact MDSI via email at tech@crmdsi.com.

Metal Design Systems, Inc.

SERIES 10

Installation Guidelines

Required Equipment:

Forklift:

Typically crates are shipped directly to the job site from our fabrication facility via LTL carrier. This means that the crates will arrive in an enclosed trailer which will require either a dock and a fork lift, or an extended reach forklift in order to unload the crates. The average crate size is 4' x 10', but they can be up to 5' x 16'. Large shipments can be delivered on flat bed trucks if prior arrangements are made.

Man-lift/Scaffolding/Ladders:

The terrain, accessibility, quantity of work on each area, and height of work will typically determine the type of lift equipment required to complete each project. The preferred option will usually be an all terrain scissor lift because they offer a larger platform allowing for more work space and fewer moves.

Work Table:

You will need a work surface to prep the panels for installation, cut penetrations, or make field modifications. The table should be large enough to safely support the largest panels on the project, and be covered with a long pile carpet to protect the panels from damage. Some installers prefer to build tables on site using the crating materials. This is perfectly acceptable provided that they are constructed in a sturdy fashion.

Power Tools:

10" or 12" miter saw with 80 tooth non-ferrous metal cutting blade for cutting extrusions; jig saw with plywood cutting blade for cutting penetrations in panels; router with carbide tipped, flat point V-bit; drill and various sized drill bits; screw gun with 5/16" hex head driver and #2 Phillips bit.

Hand Tools:

Pop-Rivet gun, rubber mallet, single-cut metal file, countersink bit, hole saw kit for penetrations, caulk gun, utility knife, single edge razor blades, tin snips, flat blade screw driver, tape measure, 4 foot level, torpedo level, (a laser or sight level can be very helpful for layout depending upon the complexity of the project), chalk line, safety glasses, work gloves, and hearing protection.

Supplies:

Always have an ample supply of fasteners in various sizes; plastic horseshoe shims in 1/4", 1/8", and 1/16" thicknesses; silicone sealant in the appropriate color; waterproof tarps to cover the crates; and shop rags.

Crew Size:

A crew size of three typically works best in most cases. This allows for two in the lift, handling and installing the panels on the wall; and one on the ground prepping panels, cutting and drilling extrusions, and for general ground support.

Unloading:

Prior to unloading the crates from the delivery truck inspect the crates for damage.

Note: Report any damage to the carrier and note the damage on the shipping tickets. The receiver must make all claims for damage through the carrier upon receipt. Metal Design Systems, Inc. is not responsible for any damage after the product leaves the factory.

Unload the material one crate at a time, know and follow all safety rules. Use the proper equipment for the weight being unloaded. If unloading with an overhead crane, use a spreader bar and nylon slings, do not "choke" the crates. Do not attempt to lift the crates by hand, drag, drop, or stack the crates.

Inspection and Inventory:

Shipping damage should be noted on the Bill of Lading and then reported to Metal Design Systems, Inc.

Note: The customer is responsible for filing a claim for freight damage with the shipping company within 24 hours of receipt. Failure to do so may result in forfeiture of the right to receive corrective action.

After verifying the condition of the product, inventory the panels and miscellaneous items and compare against the packing slip to ensure that all material is received.

Note: Notify Metal Design Systems, Inc. immediately if the quantities received do not match the packing list. Failure to do so may result in forfeiture of the right to receive corrective action.

Storage:

Store crates in a clean dry place. If the crates are to be stored outside, cover the crates to protect from the elements and ventilate to minimize heat build up (Figure 1). At the end of each work day, place loose panels back into the open crates, secure the panels, and cover the crate.

Figure 1

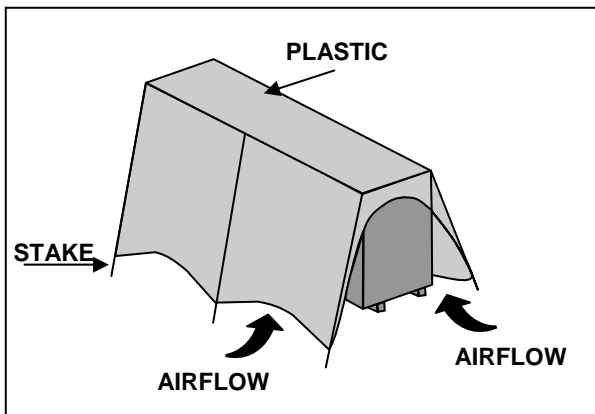

Shake Out:

Crate #1 will have a set of shop drawings revised to reflect field measurements and indicating panel part numbers and locations.

Each crate will have a packing slip indicating the part numbers and quantities of the panels enclosed. At this time it may be beneficial to boldly write the contents of each crate on the outside for future reference. If possible, strategically place each crate in a location convenient to the final destination of its contents.

Handling Individual Panels:

When removing panels from the crate, always take care to lift and clear other panels and sidewalls of the crate (Figure 2). Never slide or drag panels out of their location. When carrying the panels, always carry it “on edge” and never flat (Figure 3). Always be aware of your surroundings and take special care when handling panels that have intermediate routs or panels that have welded connections. Do not place the panels in any position that will cause the panel face or edges to come into contact with any surface that will cause damage to the protective film or panel finish. The protective film is designed to prevent minor abrasions. Extreme care should still be taken to avoid dents and scratches.

Figure 2

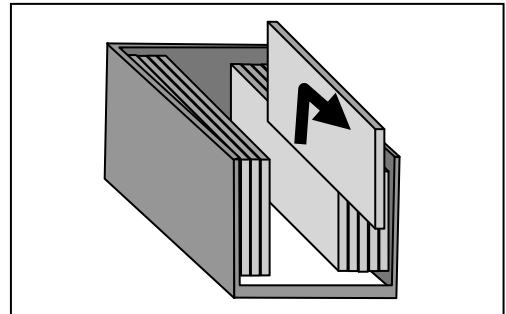
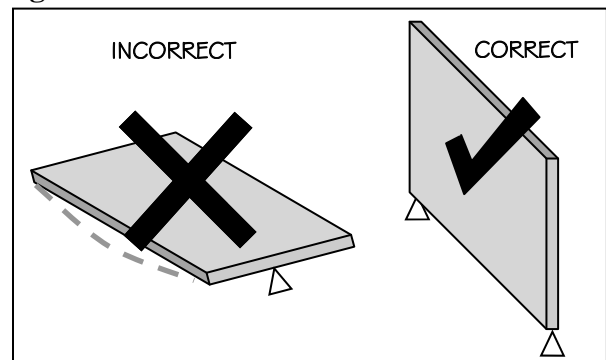

Figure 3



Substrate/ Job Inspection:

Inspect the area that is to receive the panels to ensure that all work is complete and satisfactory. All substrates, weather barriers, penetrations, doors, windows, and any other adjacent materials should be in place and cleaned prior to proceeding with panel installation.

Note: Acid wash used for cleaning masonry will cause permanent damage to the panels.

Ensure that all surfaces are plumb, level, square, true, dry, and free from defects. Do not begin installation until all unsatisfactory conditions have been corrected.

Layout:

Reference the revised shop drawings and locate key components for panel system alignment (i.e. windows, doors, window mullions, or other items that are critical to joint locations) and begin layout from these locations. Snap chalk lines at the center of each panel joint making sure that all lines are level and plumb (**Figure 4**). This will help to control panel gain or loss over a long run. If the panel system is to be installed over a gypsum board substrate, locate all framing members to ensure that all fasteners engage a structurally sound member.

Figure 4

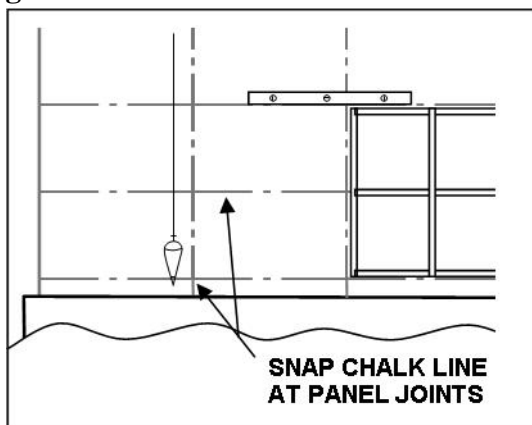

Installing Flashing and Weather Barrier:

Install flashing using standard sheet metal practices and procedures, ensuring that all joints

and seams are weather lapped and sealed. For weather barrier, follow manufactures written instructions for proper installation. Integrate weather barrier and flashing to allow proper drainage of any moisture that may enter or accumulate within the panel system.

Installing Panels

Metal Design Systems Series 10:

Setting Up:

Locate work table and miter saw in a safe and convenient location relative to the installation area. Locate the panel clips and screws for fastening clips to the panels. Screws are provided for fastening the clip to the panels but it is the installers' responsibility to provide the proper fastener type and length for attaching the clips to the substrate.

Panel Prep:

Locate the panel that is to be installed first, remove it from the crate, and inspect again for damage. Place the panel on the work table and peel back the protective film from the panel return legs. Trim off the loose film using a single edge razor blade taking care not to scratch the panel finish (**Figure 5**). If penetrations need to be cut in the panel they should be done so at this time.

Figure 5

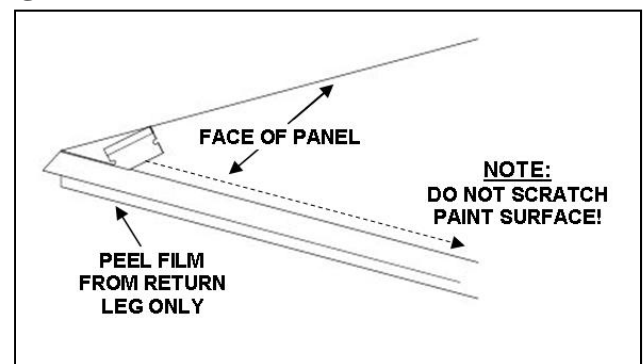

Cutting Penetrations:

Verify location and size of penetration, remembering to allow for engagement into anchor extrusions. Mark penetration on the back of the panel and drill a pilot hole within the penetration large enough for a jig saw blade.

Cut the opening from the back side of the panel using a variable speed jig saw with a plywood cutting blade (**Figure 6**). Smooth the cut with a single cut metal file.

Figure 6

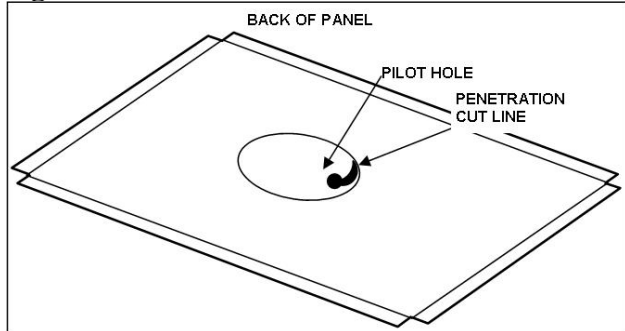

Note: If the object penetrating the panel does not have a weatherproof escutcheon, you will need to caulk around the object penetrating. Therefore, the panel will require a return leg around the opening to caulk to. Cut opening in the same manner as above except that the opening should be 1" smaller than the object penetrating the panel. Using the router and the v-bit, rout grooves around the opening 1" away from the opening (**Figure 7**).

Figure 7

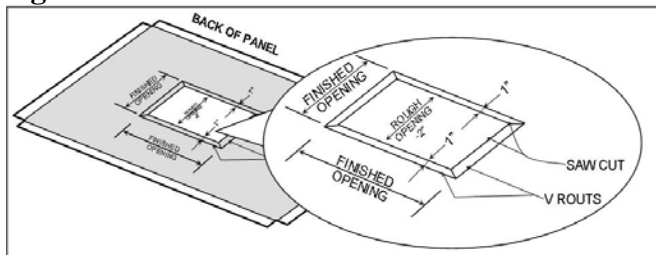

Use a fence to protect the good side of the panel and allow a clean straight rout (**Figure 8**).

Figure 8

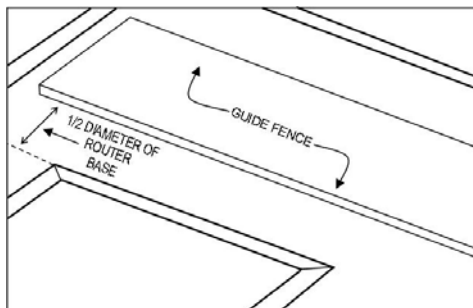

Two sided tape works well to temporarily secure the fence to back of the panel (**Figure 9**).

Figure 9

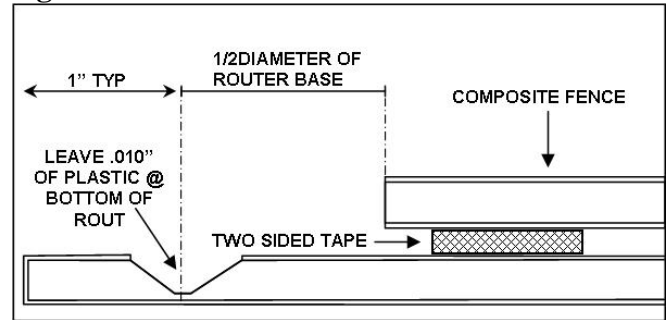

Saw cut the returns at the inside corners taking care not to cut past the v-rout (**Figure 10**).

Figure 10

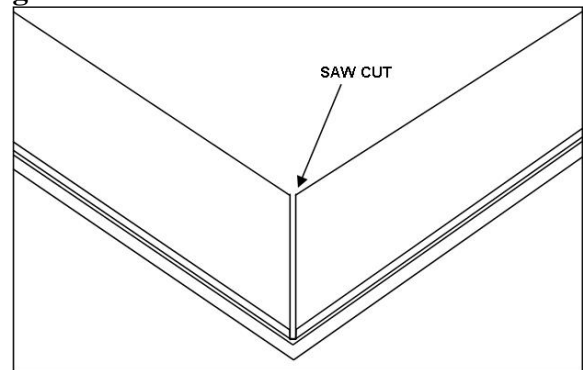

Back up the returns at the inside corners using a small piece of aluminum sheet bent to an angle. Pop-riev or screw into place (**Figure 11**).

Figure 11

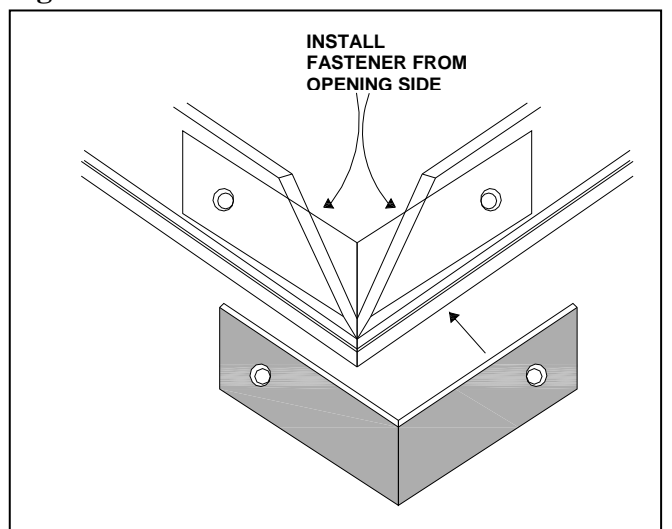

Back up angle with butyl sealant (**Figure 12**).

Figure 12

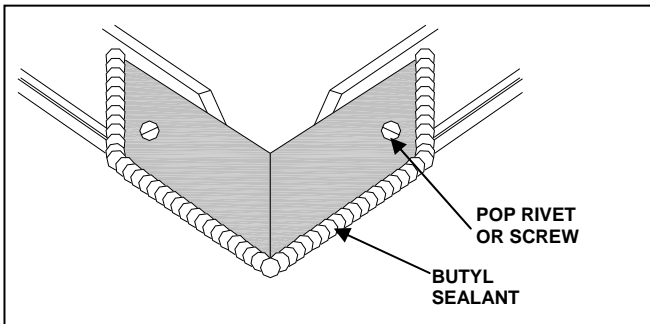

Sealing Inside Corners of Panels:

Prior to installing the panels on the wall, the corners of each panel must be sealed and reinforced. This step is typically done at the factory. Take time to double check to see that all corners have been sealed. If any corners are left unsealed, use butyl tube sealant, and squeeze a bead into the v-routs and mitered corners approximately 1” in all three directions. Back up the corner with an aluminum corner angle and two self drilling screws (**Figure 13**).

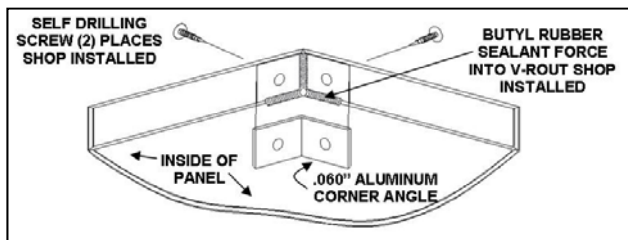
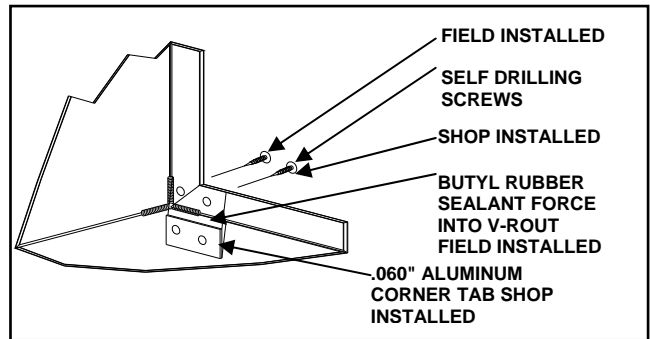

Figure 13

At intermediate routs where panels wrap around a corner or fold under a soffit, install a corner tab to reinforce the corner and seal with butyl rubber sealant (**Figure 14**).

Figure 14



Installing Panel Clips:

Pre-determine the desired locations of each panel attachment clip by locating structural members or staggering clips from previously installed panels. Start on each edge of the panel with the first clip being about 2” from the corner, then spaced a maximum of 16” on center. Clamp the clip with the 7/8” leg on the back side of the panel return and fasten with two of the screws provided (**Figure 15**).

Figure 15

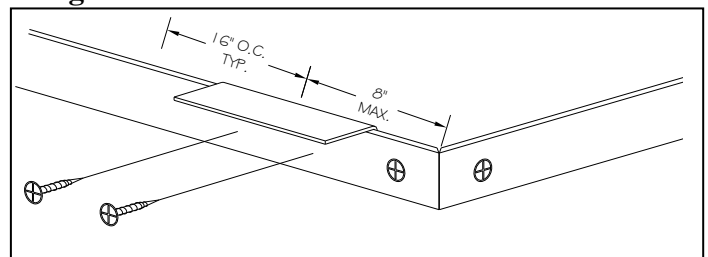

Continue installing panel clips until all edges are complete. Remember that 16” o.c. is the maximum distance that the clips can be spaced. Pay close attention that the clips will not interfere with the clips on neighboring panels.

Setting Panels:

Align panel with joint center chalk lines laid out on wall earlier. Hold panel 1/4” back from the centerline in order to maintain a nominal 1/2” panel joint. Shim packs can be used to help maintain joint spacing and align panels (**Figure 16**).

Figure 16

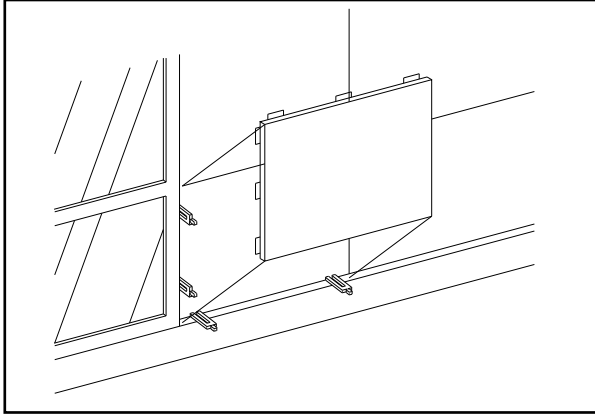

Fasten the panel clips to the wall using the appropriate fasteners. Metal Design Systems, Inc. recommends a minimum #12 stainless steel self drilling or wood screws (depending upon the substrate) spaced a maximum of 16" on center. If system is applied over a gypsum board substrate, ensure that the fasteners are located and of sufficient length to properly engage a structural member. Wood screws require a minimum of 1" penetration into the wood and self drilling screws require a minimum of three full threads extending past the back side of the metal. Shim panel clips as required to ensure a flat and true panel face. Repeat steps for prepping panels, installing clips, and fastening panels to the wall until complete (**Figure 17**).

Figure 17

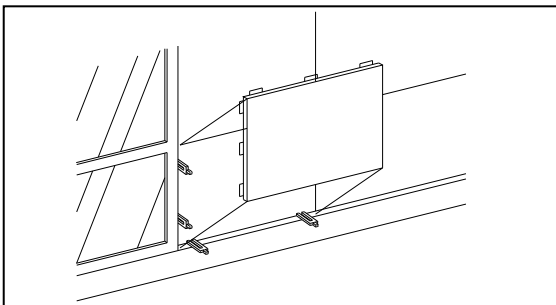

Prior to the end of each day, make sure all panels are secure so that none of the panels can become disengaged.

Removing Protective Film:

The protective film should be removed immediately after final installation of the panel

or at least at the end of each work day. Peel the film back against itself on the same plane as the panel face.

Note: The film removal process may cause a static charge to build. To reduce the possibility of static shock, ground yourself against the portion of the panel with the film removed.

Note: Panels with film left exposed to UV for extended periods of time may become difficult to remove. Panels with film partially removed and left exposed to dirt and UV rays may become discolored.

Installing Backer Rod:

Backer rods regulate the depth of the silicone sealant bead and prevent three sided adhesion in the panel joint. Use **open-cell** polyurethane backer rod which is 25-50% larger than the width of the joint, thereby extending continuous pressure against the joint walls, and expanding and contracting with the bead movement without pushing the sealant out of the joint during the compression cycle.

Note: Use open-cell polyurethane backer rod. Closed-cell backer rod may cause out-gassing or bubbling/blistering in the sealant if the rod is punctured or torn during installation.

Set the rod to a depth to where the sealant thickness will be approximately $\frac{1}{2}$ the width of the joint.

Caulking the Panel Joints:

Use clean release masking tape to mask off the panel face along each panel joint. Clean the panel joints within 1 to 2 hours of when the sealant will be applied. If required for compatibility, apply sealant primer to the return legs of the panel.

Note: Follow sealant manufacturers' cleaning, priming, and installation instructions.

Carefully fill panel joints with sealant, making sure to avoid skips and bubbles. Tool caulking to ensure full contact with joint sidewalls and to leave a smooth concaved surface (**Figure 18**).

Figure 18

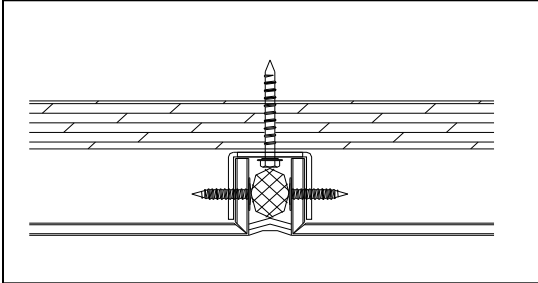

Note: Reference Metal Design Systems, Inc's. recommended sealants on the cover sheet of your project shop drawings.

Remove masking taking care to not allow wet sealant to come into contact with the panel face or any other finished surface.

Cleaning Panels:

In most cases, never use anything more than mild detergent and a soft cloth to clean the panels. Rinse with clean water immediately afterwards. See panel manufacturer's recommendations for proper cleaning methods.

Clean Up:

Keep work areas free of objects that could cause injury or damage to the panels. At the end of each work day, place all trash and debris into the appropriate containers for disposal.

**These guidelines are intended to convey the general sequences and procedures. Each application may vary and require specialized procedures. Refer to the project specific details for specialized instruction or contact Metal Design Systems, Inc.
Phone: 319-362-7454**

Revised 3/11/10